

R119 Regulators – Hi-Flow

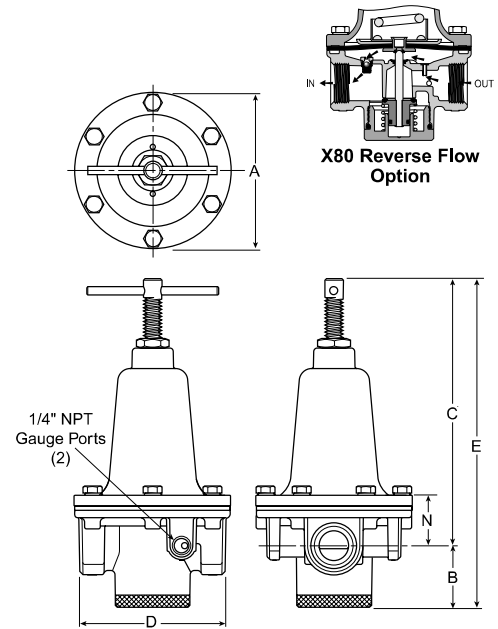

Features

- High flow performance featuring rugged design for the most demanding applications
- Ideal for those installations calling for constant pressure with wide variation in flow
- Diaphragm operated design with balanced poppet design for quick and accurate regulation
- Secondary aspiration plus balanced poppet provides quick response and accurate pressure regulation
- Heavy duty tee handle adjustment
- Reverse flow version available
- High flow: 3/4" 300 SCFM
 1" 400 SCFM
 1-1/4" & 1-1/2" 500 SCFM



Port Size	NPT Relieving
Without Gauge 0-125 PSIG Reduced Pressure	
3/4"	R119-06C
1"	R119-08C
1-1/4"	R119-10C
1-1/2"	R119-12C
With Gauge 0-125 PSIG Reduced Pressure	
3/4"	R119-06CG
1"	R119-08CG
1-1/4"	R119-10CG
1-1/2"	R119-12CG

R119 Regulator Dimensions					
A	B	C	D	E	N
R119-06C, R119-08C					
4.69 (119)	1.87 (47)	8.15 (207)	4.38 (111)	10.02 (255)	1.61 (41)
R119-10C, R119-12C					
4.94 (125)	1.81 (46)	8.53 (217)	4.94 (125)	10.34 (263)	1.99 (50.6)

inches (mm)

⚠ WARNING

**Product rupture can cause serious injury.
 Do not connect regulator to bottled gas.
 Do not exceed maximum primary pressure rating.**

Standard part numbers shown bold.
 For other models refer to ordering information below.

§ SCFM = Standard cubic feet per minute at 100 PSIG inlet, 75 PSIG no flow secondary setting, and 20 PSIG pressure drop.

Ordering Information

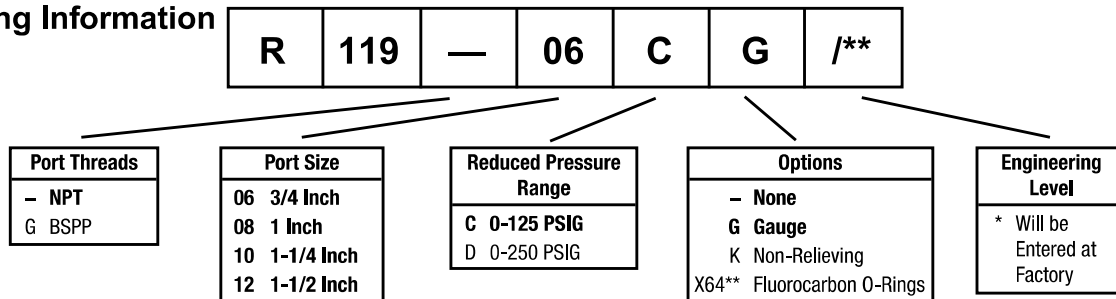

* Reverse flow for use downstream of control valves.

** Brass Bottom Plug Standard with X64 Option.

BOLD ITEMS ARE MOST POPULAR.

Technical Specifications – R119

Technical Information

**Flow Characteristics
R119-06C**

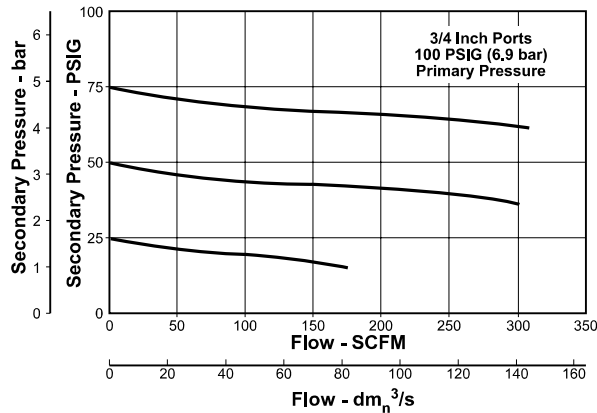

**Flow Characteristics
R119-08C**

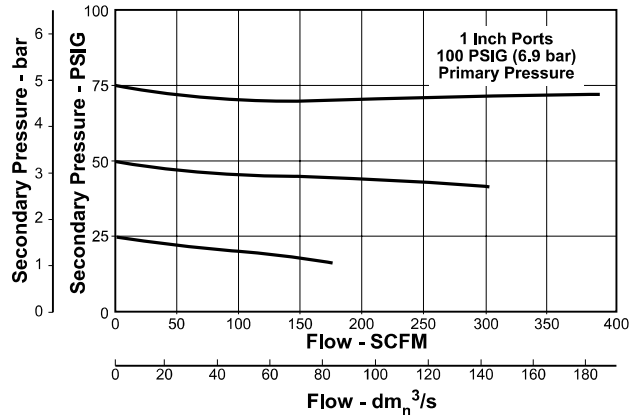

**Flow Characteristics
R119-10C**

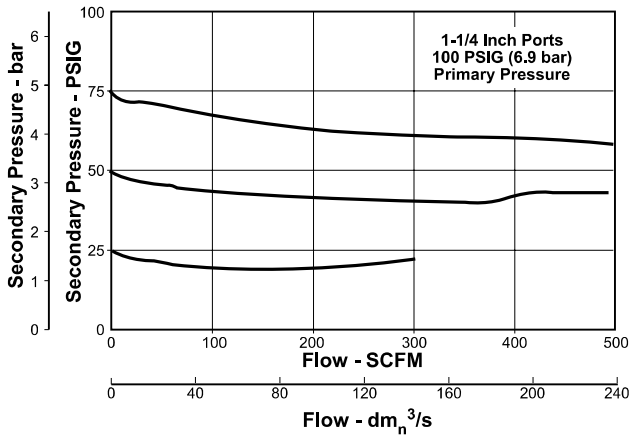

**Flow Characteristics
R119-12C**

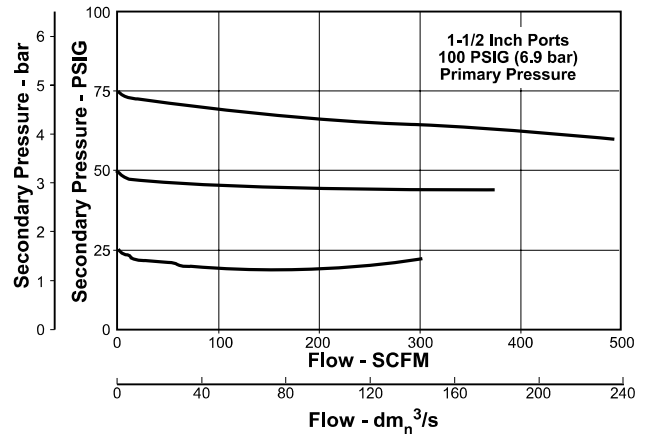

R119 Regulator Kits & Accessories

Gauges –

2" Dial Face

- 60 psig (0 to 4.1 bar)..... K4520N14060
- 160 psig (0 to 11.0 bar).....K4520N14160
- 300 psig (0 to 20.0 bar)..... K4520N14300

1-3/4" Digital Round Face

- 160 psig (0 to 11.0 bar)..... K4517N14160D

Mounting Bracket Kit 18B57

Repair Kits –

- Non-Relieving Diaphragm,
Valve Assembly (3/4", 1") RK118B
- Non-Relieving Diaphragm,
Valve Assembly (1-1/4", 1-1/2") RK118D
- Relieving Diaphragm,
Valve Assembly (3/4", 1") RK119B
- Relieving Diaphragm,
Valve Assembly (1-1/4", 1-1/2") RK119D

For Fluorocarbon Repair Kits, add X64 to Kit Number suffix.

Specifications

- Gauge Ports (2)**1/4 Inch
- Port Threads** 3/4, 1, 1-1/4, 1-1/2 Inch
- Reduced Pressure Range** 2 to 125 PSIG (0.15 to 8.5 bar)
- Supply Pressure** 300 PSIG Maximum (20.4 bar)
- Temperature Rating** 40°F to 125°F (4.4°C to 52°C)
- Weight –**
- R119-06, R119-08 6.2 lb. (2.81 kg) / Unit
25 lb. (11.34 kg) / 4-Unit Master Pack
- R119-10, R119-12 7.2 lb. (3.27 kg) / Unit
29 lb. (13.15 kg) / 4-Unit Master Pack

Materials of Construction

- Adjusting Screw, Springs** Steel
- Body, Spring Cage**Zinc
- Bottom Plug, Innervalve** Brass
- Seals** Buna N

